



Series FSB 11

Standard 1-Piece

Reduced Port Ball Valves

1/4" – 2" (DN8 – DN50)

2000 psi (PN130)



www.valvesolution.com.au



FIRE-SAFE



ANTI-STATIC



GUARANTEE
SAFETY

Simple Design with Fire-Safe

DIE ERSTE Series FSB 11 features one piece and reduced port design. It can be used in general applications such as hydraulic, chemical, steam, oil/gas, and oxygen, Series FSB 11 can also be used in fire-safe condition, where condition requires higher pressure resistance and higher temperature resistance.

The original one-piece and retainer screw-in design gives the advantage of avoid using excess body pieces. The screw-in retainer design provides extra body strength and lowers leaking possibility to minimum. DIE ERSTE provides fully retraceable heat number for references with our high quality investment cast foundry.

Series FSB 11 is equipped with fire-safe package, including fire-safe lip, fire-safe graphite body seal and stem packing, and anti-static device on the stem. Similar to other FSB products, fire-safe lip is precision machined to perfectly match the ball, so that in the case of fire destroying ball seat, the ball becomes in contact with the fire-safe lip. Thus, a new metal-to-metal seat is created. The graphite body seal and stem packing are able to sustain under high temperature condition, and not be decomposed. Graphite seals are unable to contaminate the fluid since they are trapped and immobile in the bore; even in high pressure condition graphite may be fragmented.

Series FSB 11 have a simple mounting pad for automation purposes. Generally one piece ball valve does not require mounting pad design, but DIE ERSTE Series FSB 11 offers the possibility. The two holes on the neck section connect custom- designed bracket plus an adapter, actuators or automation accessories can be used in Series FSB 11 ball valves.

Valve Body Rating with Seat Material Plot

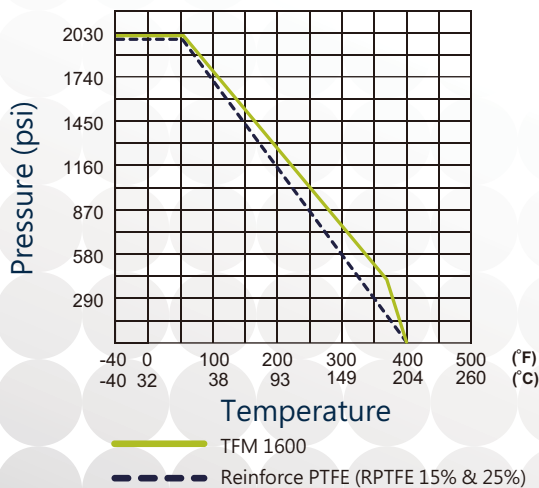

CE marking 0035

The whole series of ball valves are approved according to European Directive 97/23/EC.

Blowout-Proof Design

The stem is installed from the bottom-entry direction instead of top-bottom. This prevents stem to shoot out during unexpected accident, and further provides a safer valve using environment. This design is widely used in DIE ERSTE's ball valves.

Pressure Rating

2000 psi (PN130) WOG
150 psi (10 bar) with saturated steam

Temperature Range:

- -20°F to 400°F (-28°C to 200°C) with TFM 1600 seat
- -20°F to 400°F (-28°C to 200°C) with RPTFE seat

End Connection:

Female pipe thread that meets NPT, DIN 259/2999, and BS21 regulations. FSB 11 does not have butt-welding and socket-welding connections. For more end connection, please contact with our sales representatives.

Body Material:

ASTM CF8M, CF8, WCB
(DIN 1.4408, 1.4308, 1.0619)

Size Range:

1/4" ~ 2" (DN8 ~ DN50)

Standards and Specifications

Female Thread end-to-end length meets
NPT, DIN 259/2999, and BS21

Valve body and end cap connections are high quality investment cast. Stainless steel can be special processed with anneal, and carbon steel can be normalized, both are upon request. Other valve components, such as valve body, end cap, and stem, are produced to follow the ASME and other international regulations. All the valves are factory tested to meet API and MSS standards to ensure the quality of the valves.

Certifications of FSB 11

API 607 4th Edition
Certified

API 607 Fire Test for Soft seated
Quarter Turn Valves

CRN
REGISTERED 

Canadian Registration Number



ATEX Directive 94/9/EC
Explosive Prevention

Series FSB 11 1pc Ball Valve

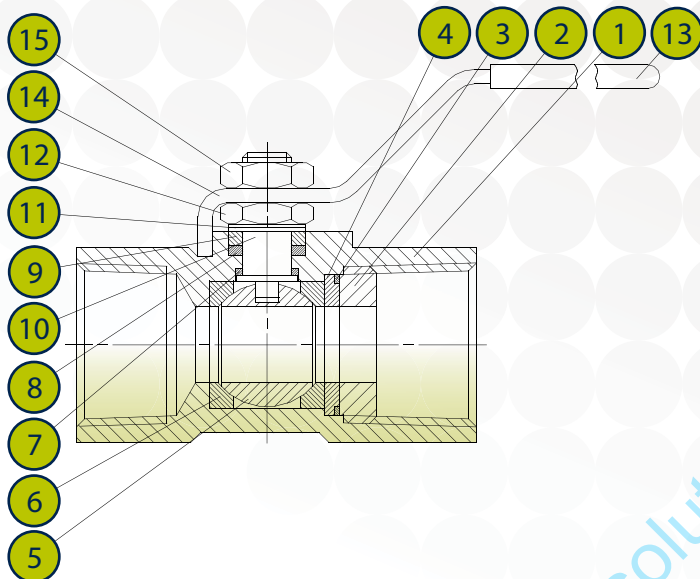

NO	PART NAME	MATERIAL
1	BODY	CF8M / WCB
2	RETAINER	SS 316
3	BODY SEAL	GRAPHITE
4	SEAT RETAINER	SS 316
5	SOLID BALL	CF8M
6	BALL SEAT	TFM 1600 RPTFE 15%
7	THRUST WASHER	PTFE / GRAPHITE
8	STEM PACKING	GRAPHITE
9	GLAND RING	SS 304
10	STEM	SS 316
11	BELLEVILLE SPRING	SS 301
12	NUT	SS 304
13	HANDLE SLEEVE	VINYL
14	HANDLE	SS 304
15	HANDLE NUT	SS 304

Dimensions inch/mm

SIZE Inch DN	d	L	H	W	A	B	M
1/4"	0.36	2.64	1.81	4.33	0.5	1.12	10-24UNC
8	9.2	67	46	110	12.7	28.5	10-24UNC
3/8"	0.36	2.64	1.81	4.33	0.5	1.12	10-24UNC
10	9.2	67	46	110	12.7	28.5	10-24UNC
1/2"	0.36	2.64	1.81	4.33	0.5	1.12	10-24UNC
15	9.2	67	46	110	12.7	28.5	10-24UNC
3/4"	0.50	2.80	1.97	4.33	0.5	1.12	10-24UNC
20	12.5	71	50	110	12.7	28.5	10-24UNC
1"	0.63	3.31	2.36	5.51	0.87	1.37	10-24UNC
25	16	84	60	140	22.1	34.8	10-24UNC
1 1/4"	0.79	3.70	2.56	5.51	0.87	1.37	10-24UNC
32	20	94	65	140	22.1	34.8	10-24UNC
1 1/2"	0.96	3.94	2.83	6.3	0.93	1.50	1/4"-24UNC
40	24.5	100	72	160	23.6	38.1	1/4"-24UNC
2"	1.26	4.65	3.07	6.3	0.93	1.50	1/4"-24UNC
50	32	188	78	160	23.6	38.1	1/4"-24UNC

